

# Background: Definitions

---

- Polarization is the amount of charge associated with the dipolar or free charge in a dielectric
- Pyroelectricity: when temperature increased, electric charges appear on the surface of the crystal (tourmaline the “Ceylon magnet,” 1703)
- Ferroelectrics: materials in which spontaneous polarization can be altered by electric field.
- Ferroelastics: materials in which mechanical stresses alter the spontaneous polarization.
- Piezoelectric: material in which application of stress generates electric charges on its surfaces; implies “direct piezoelectric effect”
- Electrostriction is a secondary coupling in which the strain is proportional to square of the electric field; frequently implies the “inverse piezoelectric effect.”
- Direct piezoelectric effect: convert mechanical energy into electrical (Pierre Currie in 1880)
- Inverse effect: convert electrical energy into mechanical (Lippman from thermodynamic principles; Currie experimentally in 1881)

# Background: Piezoelectric Effect

- Electric field  $E = \frac{V}{d}$

- Dielectric displacement (flux)  $D = \frac{q}{A}$

- Constitutive equations

$$s_{ij} = S_{ijkl}^E \sigma_{kl} + d_{ijk} E_k$$

$$D_i = d_{ijk} s_{jk} + \epsilon_{ij}^E E_j$$

- Electro-mechanical coupling:

$$K^2 = \frac{\text{stored mechanical energy}}{\text{input electrical energy}} = \frac{\text{stored electrical energy}}{\text{input mechanical energy}}$$

- Electrostatic

$$D_i = \epsilon_{ij} E_j$$

- Elastic

$$s_{ij} = S_{ijkl} \sigma_{kl}$$

- Equilibrium

$$\sigma_{ij,j} = -f_i$$

$$D_{i,i} = \rho$$

- Displacement

$$s_{ij} = \frac{1}{2} (u_{i,j} + u_{j,i})$$

$$E_i = -\phi_{,i}$$

# Background: First Piezoelectrics

- Quartz:
  - + great physical and chemical stability
  - small coupling coefficient
  - applications: oscillators and resonators
- Rochelle salt ( $\text{NaKC}_4\text{H}_4\text{O}_6 \cdot 4\text{H}_2\text{O}$ ):
  - + great piezoelectric effect
  - water soluble and had poor temperature characteristics
  - applications: various transducers such as a phonograph pickups

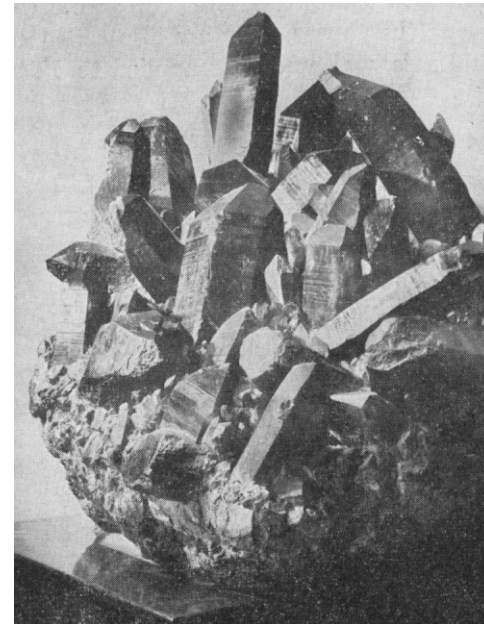
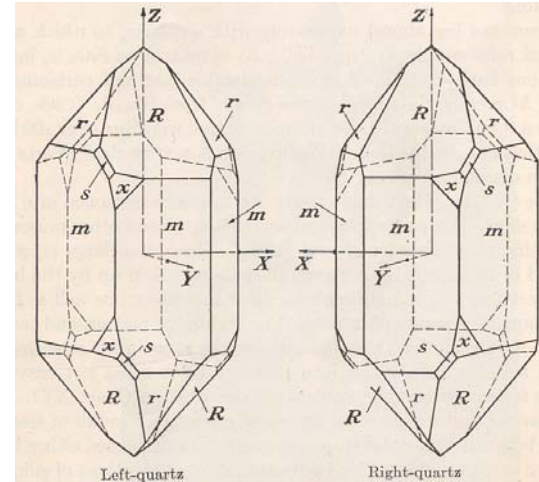

Quartz crystal (from Cady, 1946)

# Background: Barium Titanate

- Perovskite structure:  $\text{ABO}_3$
- The absence of center symmetry in crystal structure gives rise to spontaneous polarization
- Cubic above Curie temperature; tetragonal as it cools down.
- Barium –Titanate ( $\text{BaTiO}_3$ )
  - the first material to be developed as a piezoceramic
  - available in single crystal form
  - Discovered independently
    - United States (Wagner and Salomon 1942)
    - Soviet Union (Wul and Goldman, 1945)
    - Japan (Miyake and Ueda, 1946).
  - Applications: detection of mechanical vibration, actuators, and for generation of acoustic and ultrasonic vibrations.

*Crystal structure of Barium Titanate*

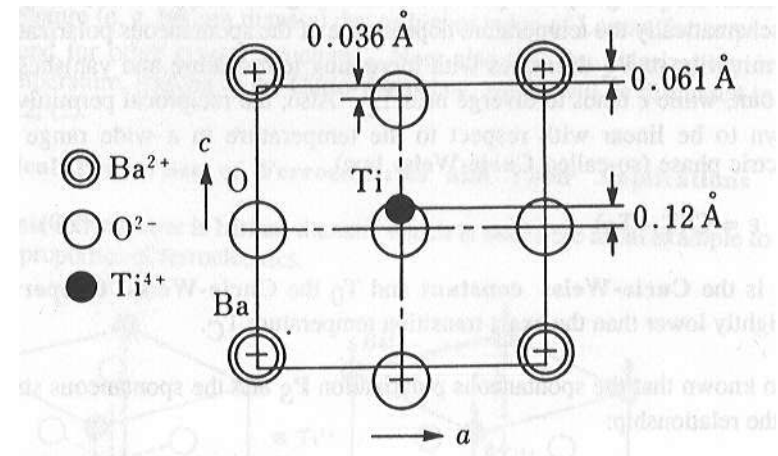

Uchino, 1997

# Background: PZT

- PZT solid solution:  $\text{PbTiO}_3 / \text{PbZrO}_3$ 
  - tetragonal system ( $\text{PbTiO}_3$ ): 6 poling directions
  - rhombohedral system ( $\text{PbZrO}_3$ ): 8 poling directions
- Discovered in 1955:
  - Takagi, Shirane, Sawaguchi, Japan.
  - Jaffe, United States
- High coupling coefficient
- High Currie temperature
- Not available as single crystal
- Various compositions
  - PZT-4, PZT-5, PZT-5A, PZT-5H (NAVY)
- New devices such as ceramic filters and piezoelectric igniters

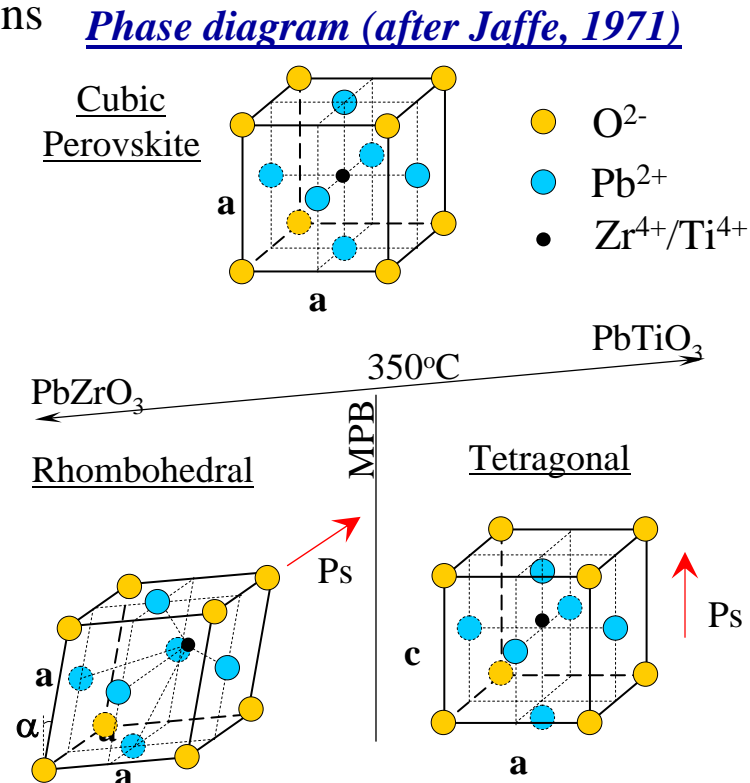

# Background: Polarization Reversal

## 180° polarization reversal:

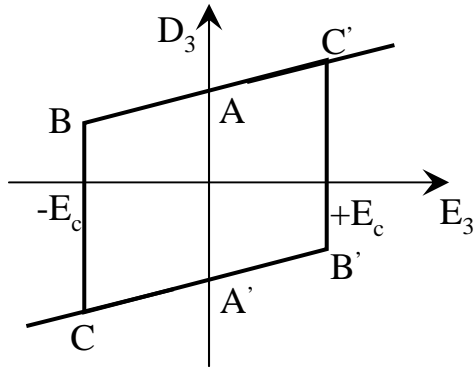

a)

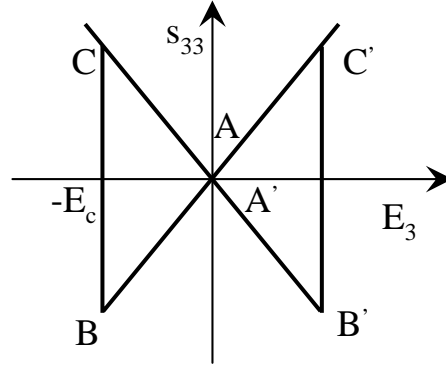

b)

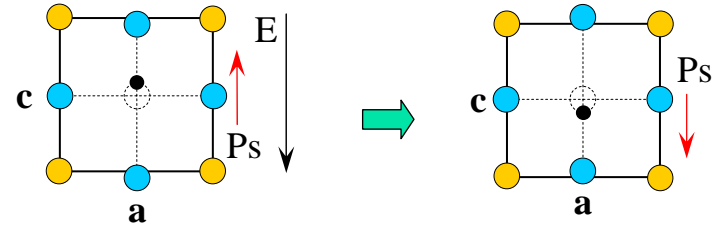

## 90° polarization reversal:

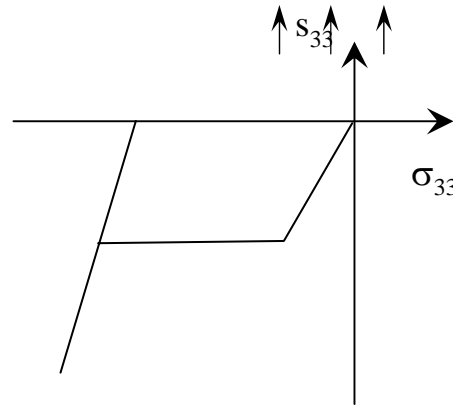
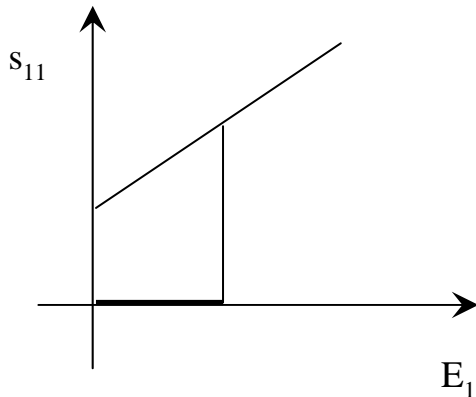
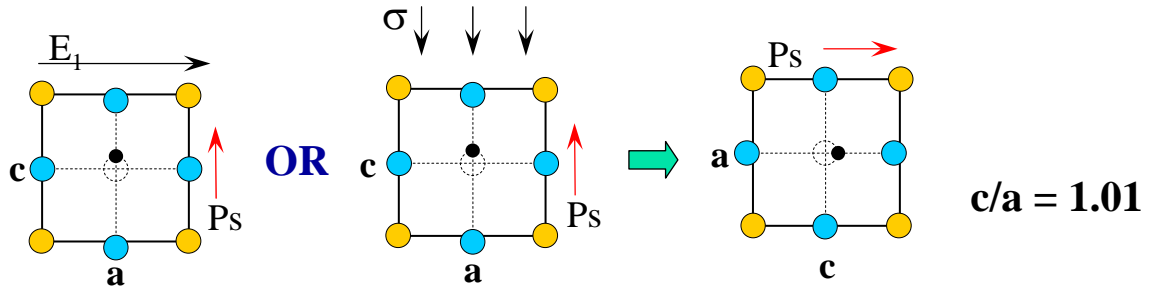

# Background: Ferroelectric Domains

- Ferroelectric domain: region with constant polarization direction
- Lower energy state
- $180^\circ$  and non- $180^\circ$  ( $90^\circ$  and  $71^\circ/109^\circ$ ) domains

## Literature :

- Mathias et al (1948):
  - existence of domains in  $\text{BaTiO}_3$
- Merz, 1952:
  - observed antiparallel  $180^\circ$ ; studied nucleation and growth; the  $180^\circ$  wall is only one or few lattice constants thick; wall energy  $\sim 10 \text{ egr/cm}^2$
- Forsbergh (1949): (101) twin planes; respond to stress
- Little, 1955: domain wall dynamics and interaction
- Berlincourt and Krueger: 1959: switching is predominantly non- $180^\circ$  domain reversal



Jaffe, 1971

# Background: Ferroelectric Domains

## Literature :

- Uchida and Ikeda, 1967
- Gerthsen and Kruger, 1976
- Kruger, 1976
  - Electric fields  $\Leftrightarrow$  both  $180^\circ$  and  $\text{non-}180^\circ$  domain walls motion
  - Mechanical stresses  $\Leftrightarrow$  only  $\text{non-}180^\circ$  domain wall motion
- Intrinsic: due to deformation of a unit cell
- Extrinsic: due to domain wall motion



- Polarization  $\Leftrightarrow$  motion of both  $180^\circ$  and  $\text{non-}180^\circ$  domain wall
- Strain  $\Leftrightarrow$  motion of only  $\text{non-}180^\circ$  domain wall

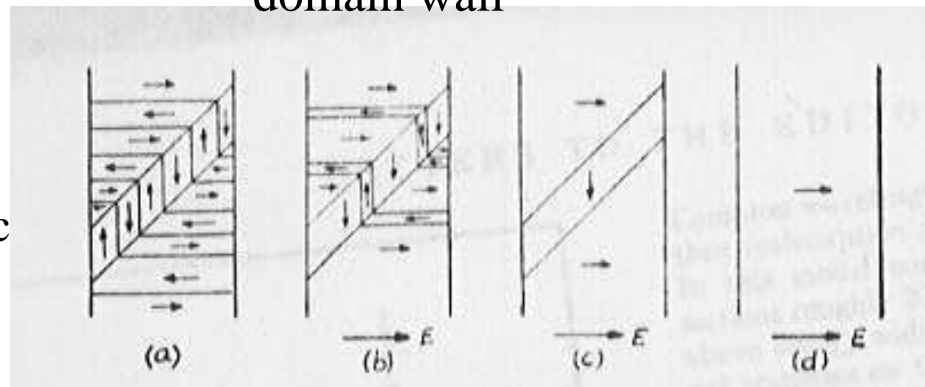

Merz, 1952

# Background: Effect of Mechanical Prestress

---

- Krueger and Berlincourt (1961); Krueger (1967, 1968)
  - the first extensive study; PZT-4, PZT-5, BaTiO<sub>3</sub>, PZT-5A, PZT-5H
  - exposure to stress, temperature, or electric field was to found to begin a new aging cycle in the ceramic
  - hard ceramics show better property recovery than soft ceramics; hard ceramics are superior for high-power high stress application
  - permittivity generally increases with stress applied parallel poling direction, and decreases with stress perpendicular to the poling direction
- Meeks and Timme (1975)
  - comprehensive comparative study (Navy I, II, III)
  - d<sub>33</sub> peaks at 60 and 120 MPa for type –I and –III but not for type –II
  - dielectric constant peaks for all three ceramic compositions
  - dielectric loss tangent showed peaks for types I and III at 80 and 150 MPa which coincided with the peaks in dielectric constant.
  - attributed peaks to a phase transition from the ferroelectric tetragonal to the ferroelectric rhombohedral
- Butler et al (1994):
  - extensive literatures review Navy I and III
  - “high” mechanical stress and electrical drive conditions
  - 0.39—0.59 MV/m and 69—103 MPa (10-15 kpsi)

# Background: Effect of Mechanical Prestress

---

- Lynch (1996):
  - PLZT ceramic; full polarization reversal at constant prestress values up to 60 MPa
  - compressive stresses reduce the remnant polarization, change the piezoelectric coefficients, and decrease the coercive field
- Hackenberger et al. (1999)
  - PZT-5H ceramics
  - a quasi-linear regime (i.e., below coercive field); prestress up to 100 MPa
  - observed peak in strain and polarization output; attributed to non-180° domain wall motion
- Prestress: about 30 references, only 3-4 relevant--depends how you count
  - descriptive technical reports
  - comparison of different materials rather than physical phenomena
  - dielectric performance rather than actuator point of view
  - low field operating conditions
  - there are no analytical models that predict peaks in the response
  - have not found comprehensive study of PZT-5H under combined loading

**There is little stress/temperature/electric field data for the PZT compositions that have been around for over forty years**